

WOOD AFT SECTION WITH COMPARABLE "C" DIMENSIONS
Scale 1-1/2" = 12"

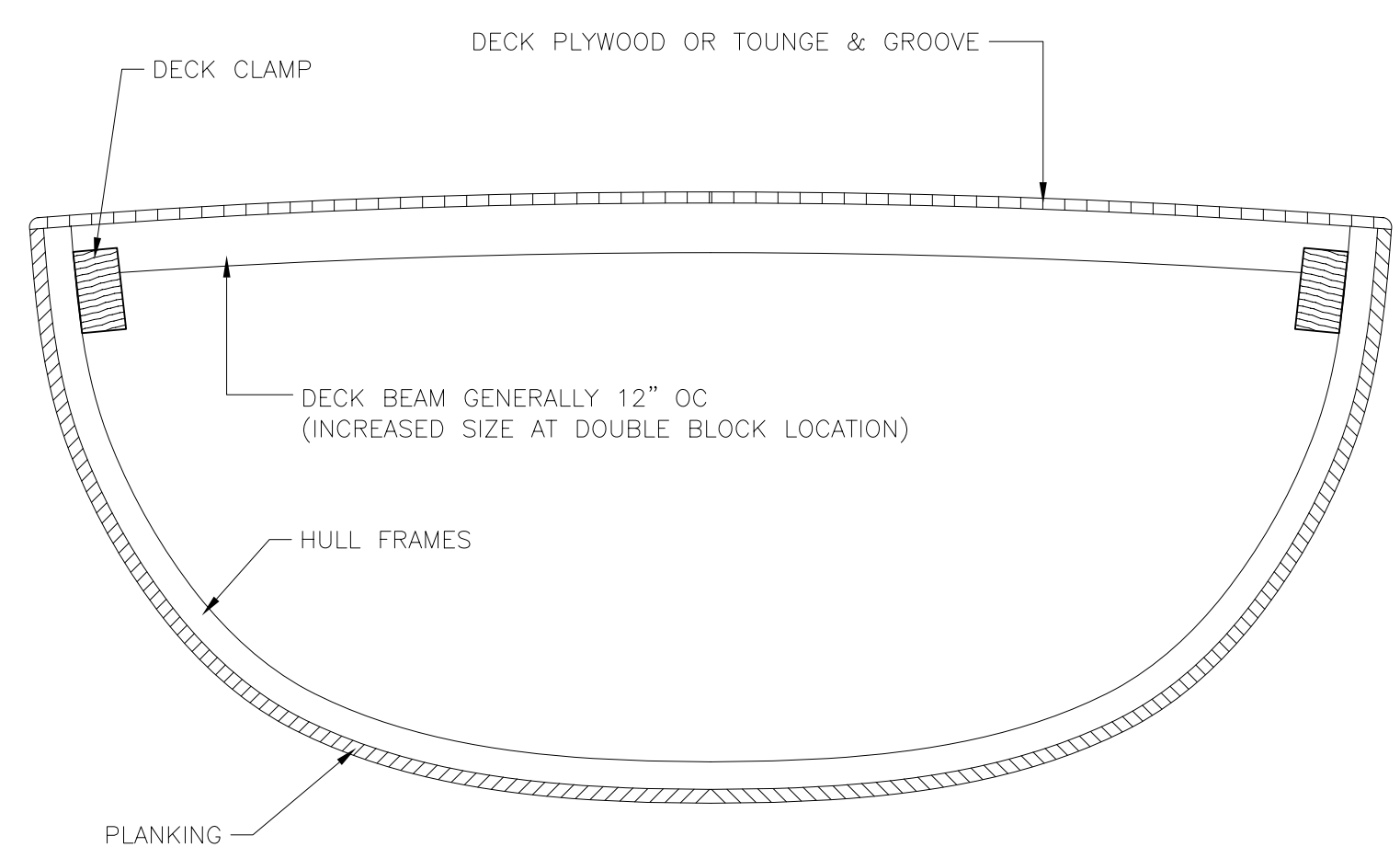

WOOD SECTION @ TRAVELER
Scale 1 1/2" = 12"

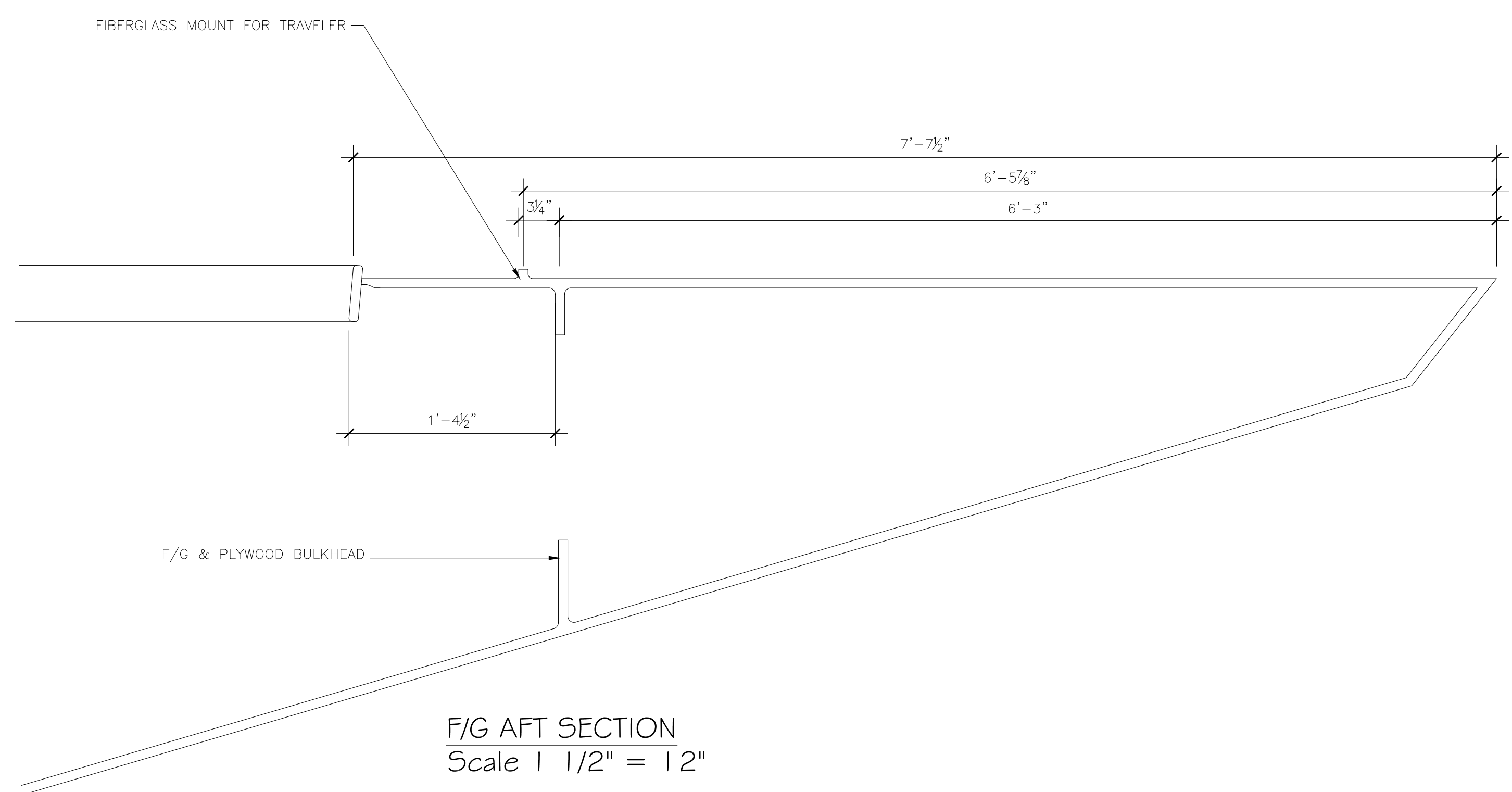

F/G AFT SECTION
Scale 1 1/2" = 12"

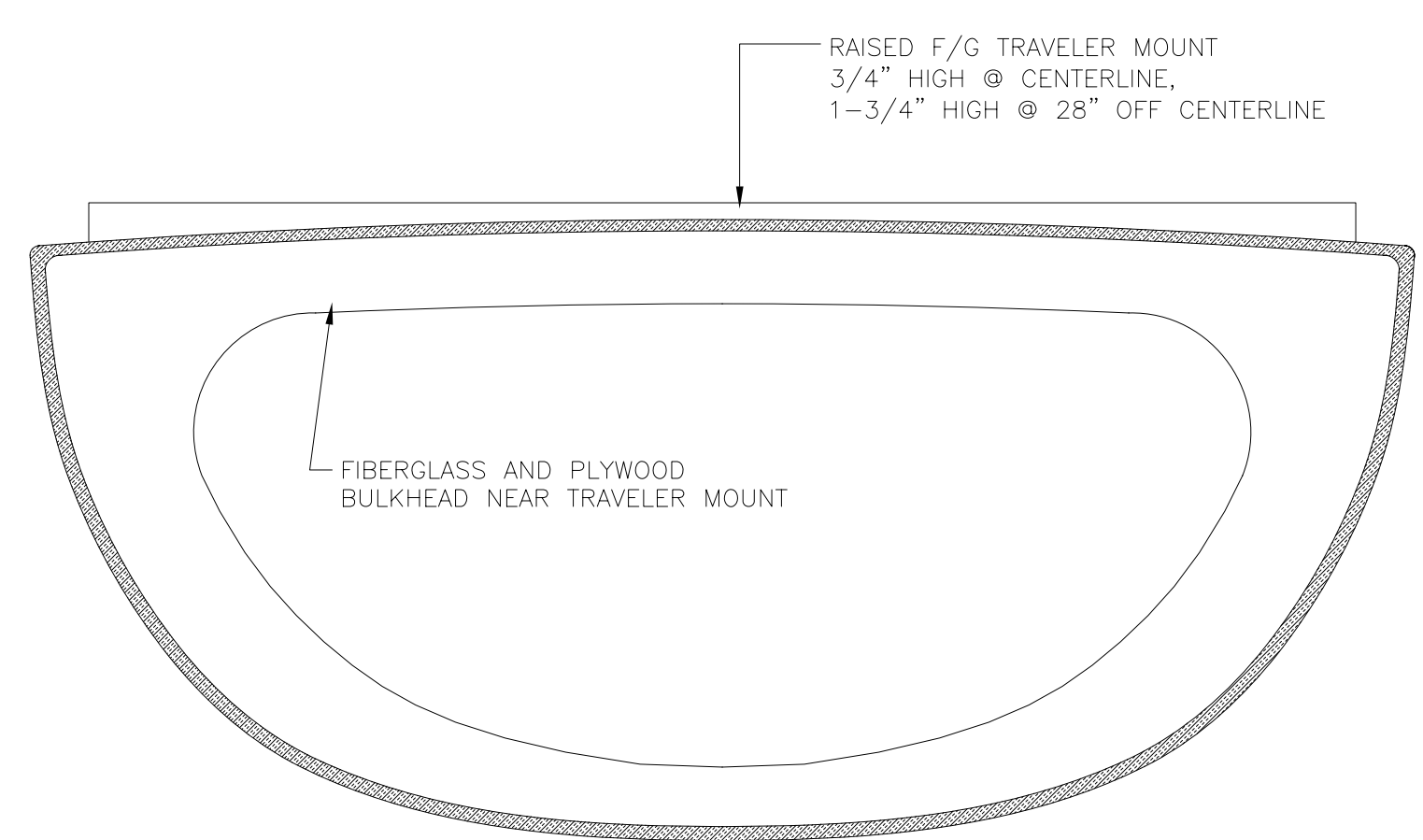

F/G SECTION @ TRAVELER
Scale 1 1/2" = 12"

GARANT ENGINEERING, INC.
General Contractors (CGC 14465) - Professional Engineers (EB 9623)
PO Box 668 Islamorada, FL 33056 - (305)-664-5464 - email: rgarant@bellsouth.net

IOD TRAVELER
San Francisco Fleet

EXISTING SECTIONS

DRAWING FILE:
xxxxxxx.dwg
DRAWN BY RRG
Date: xx/xx/03
REVISION DATE:

SHEET NO.
1

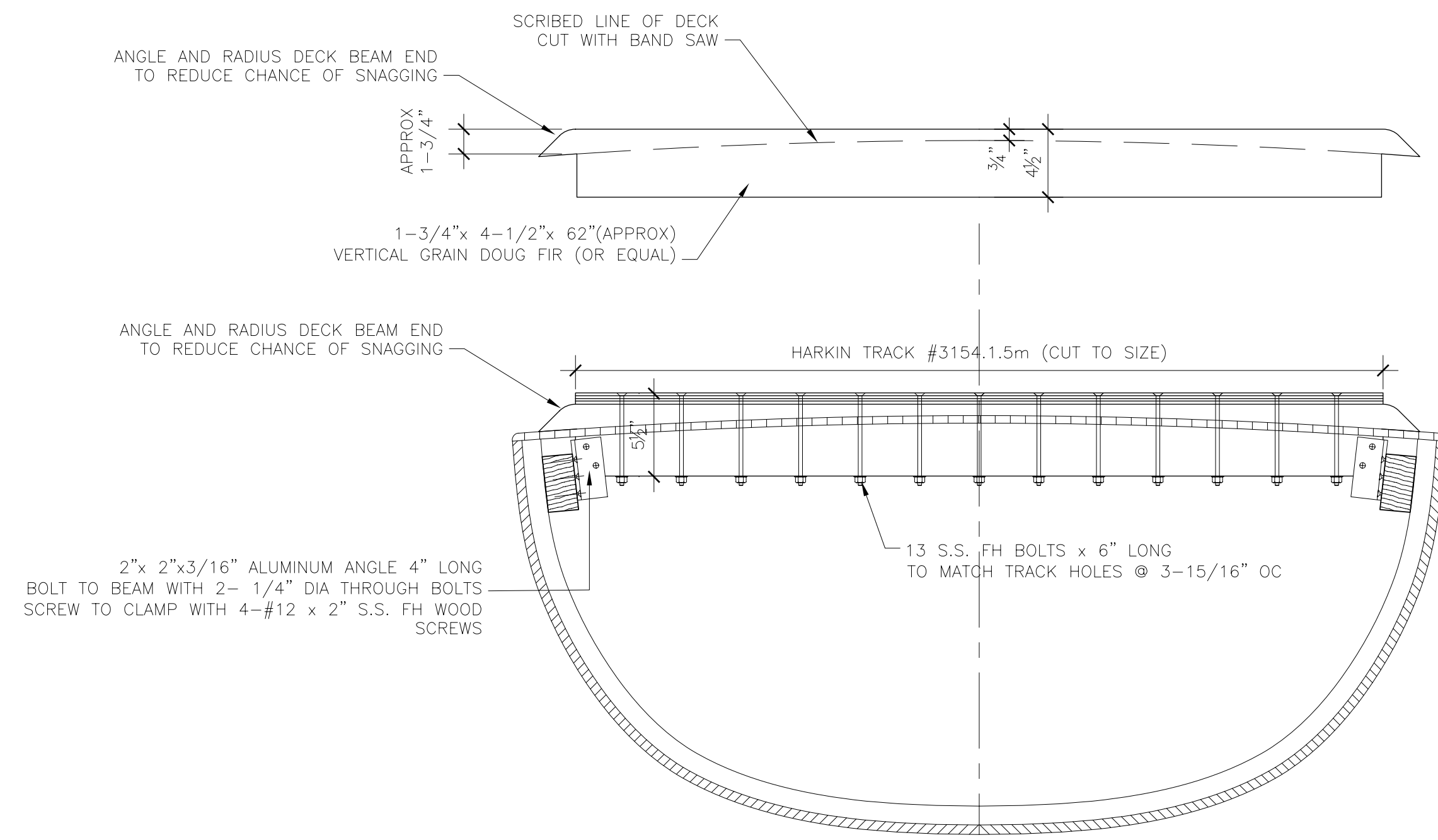

SECTION WITH BEAM
Scale 1-1/2" = 12"

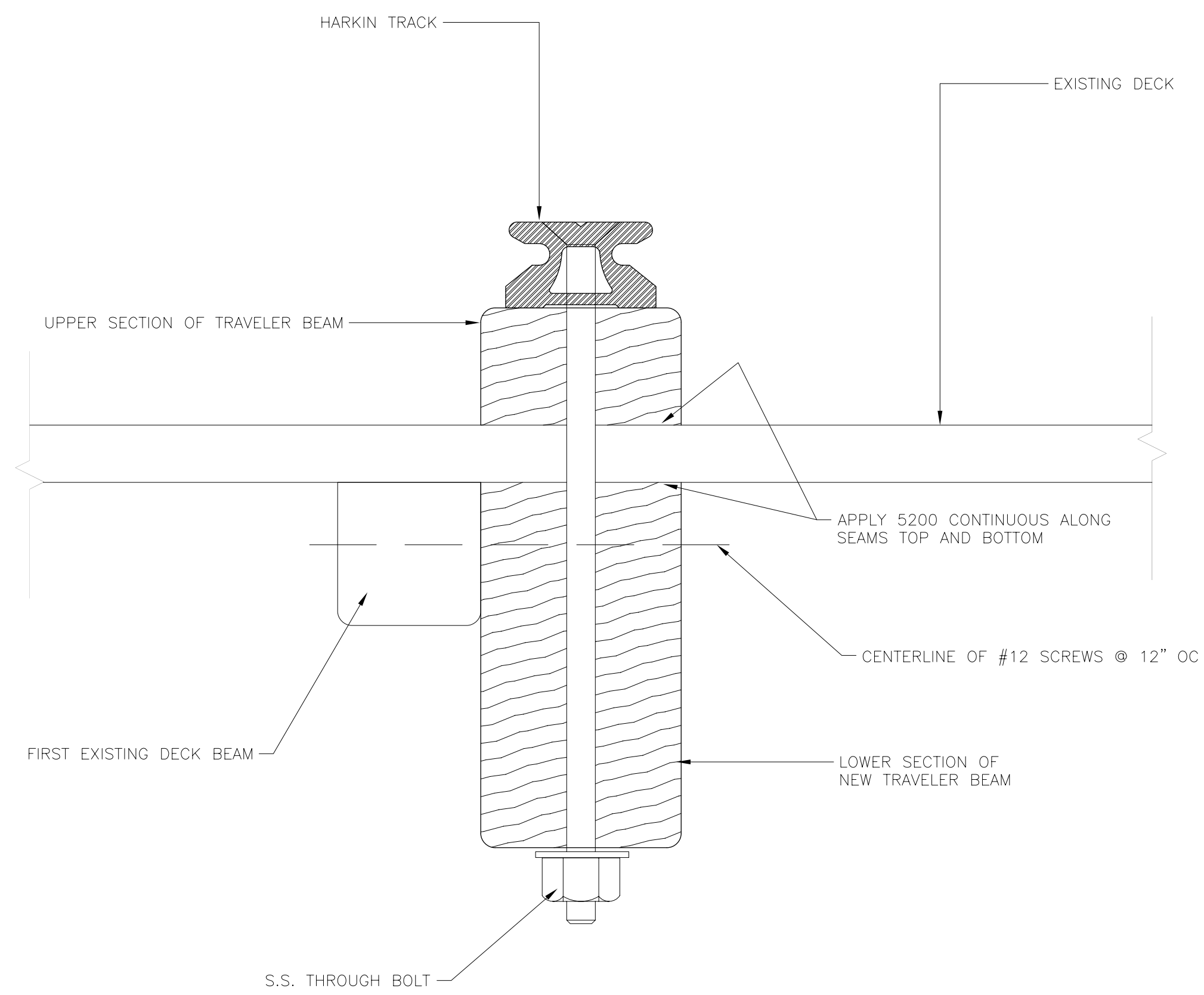

TRAVELER TRACK SECTION- WOOD BOATS
Full Scale

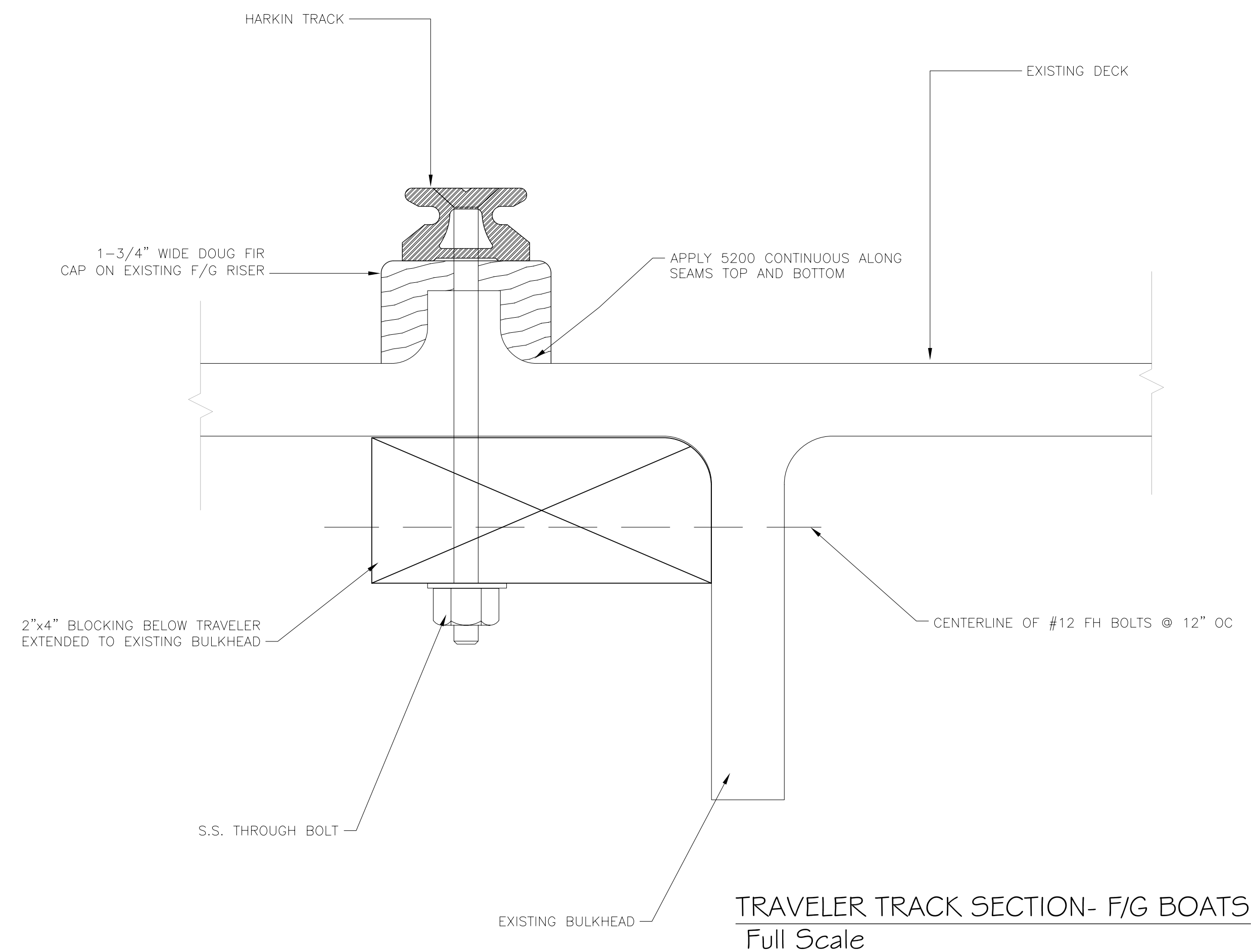

TRAVELER TRACK SECTION- F/G BOATS
Full Scale